



AIRTRUST
Compressed Air Solutions



AIRTRUST
Compressed Air Solutions

WE DESIGN IDEAS TO SHAPE THE FUTURE

We amaze our customers with state-of-the-art solutions: with this objective in mind, we have inspired the market and anticipated the future of Compressed Air Market in Iran since 2015. AIRTRUST is one of the leading companies in the production and trade of Compressed Air Packages (including air compressors, air treatment equipment, etc.) and Air Separation Units (PSA) for production of industrial gases like Oxygen, Nitrogen, etc.

The unique reliability of our products and the continual development of technical innovations allow us to meet the needs of our customers in several aspects. We have always been in the forefront in designing new solutions: among the important ones, we can mention our proficient engineering team in distinguishing defects residing in our clients' existing compressed air & gas systems and presenting them the most economical upgrading solutions before proposing a replacement package.





“
GOOD AIR,
GOOD PRODUCT,
GOOD LIFE
”

INDEX:

Compressed Air Packages (Oil-Injected) 6-12

- Direct Drive Air Compressors (ATD Series)
- Variable Speed (ATV Series)
- Belt Driven (ATB Series)
- Air Blowers

Parts and Components 14-17

- Genuine Parts & Consumables
- Zeolites & CMS
- Air Purity System Planner

Air Treatment Equipment 20-27

- Heated Air Dryers (ATH Series)
- Heatless Air Dryers (ATE Series)
- Refrigerant Air Dryers (ATR Series)
- Receiver Tanks
- Accessories
- Water Separators
- Active Carbon Tower
- Piping System

Compressed Air Packages (Oil-Free) 30-33

- Screw/one-stage (Lento Series)
- Screw/Two-stage (Simplexx Series)

Industrial Gas Generators 36-43

- Nitrogen Generators (Modular)
- Nitrogen Generators (Twin Tower)
- Oxygen Generators (Modular)
- Oxygen Generators (Twin Tower)

Centrifugal Air/Gas Compressors 44

ROTARY SCREW AIR COMPRESSORS (OIL INJECTED)

ATD SERIES

Direct Drive Model

AIRTRUST ATD Series of rotary screw air compressors offer the very best of time-proven designs and technologies with new, advanced features that ensure the highest levels of reliability, efficiency and productivity available. The unique design of ATD direct drive model offers several benefits to users. Most critically, direct drive compressors have fewer moving parts and, as a result, fewer components that can incur wear and tear. This quality makes them better-suited for heavy duty industrial applications comparing to belt-driven models.

Main Features:

- 15 (kW) to 450 (kW)
- Superior Package Design
- Air-cooled / Water-cooled
- Flange-Mounted Motor and Air End
- Premium Efficient SIEMENS Motor
- Microprocessor Controller
- Continuous operation at temperatures of up to 40 degrees C°
- Reduced energy costs
- Service-friendly design



Model	Flow (m3/min)			Power (kw)	Motor speed (RPM)	Noise (dB)	Connection (inch)	Dimensions (mm)			Weight (kg)
	8 bar g	10 bar g	13 bar g					L	W	H	
ATD 15	1.35	1.3	1.25	15	3000	78	1"	1200	1100	1400	600
ATD 22	2.85	2.65	2.5	22	3000	78	1"	1200	1100	1400	800
ATD 30	4.2	4	-	30	3000	78	1 1/2"	1800	1300	1600	1000
ATD 37	5.2	5.4	-	37	3000	78	1 1/2"	1800	1300	1600	1300
ATD 45	5.78	5.65	5.3	45	3000	78	1 1/2"	1800	1300	1600	1350
ATD 55	6.78	6.72	6.6	55	3000	78	1 1/2"	1800	1300	1600	1550
ATD 75	11.52	11.2	-	75	3000	78	2"	3000	1700	2100	2250
ATD 90	-	--	11.47	90	3000	78	2"	3000	1700	2100	2960
ATD 132	21.8	-	-	132	3000	78	3"	3000	1700	2100	3250
ATD 160	22.5	22.1	19.9	160	3000	78	3"	3000	1700	2100	3960
ATD 200	-	-	22	200	3000	78	4"	3500	2000	2100	4550
ATD 250	44.5	-	-	250	3000	78	4"	3500	2000	2100	5950
ATD 315	44.5	44	-	315	3000	78	4"	4100	2100	2100	6100
ATD 355	44.5	44	43	355	3000	78	4"	4100	2100	2200	6200
ATD 450	69.9	63.1	58	450	3000	78	4"	4100	2100	2200	8500



ATS SERIES

A Smart Option:

AIRTRUST offers "Specially Designed" direct drive compressors as "ATS SERIES" which provide following values & benefits:

- Working at 1500 rpm:
 - Half of the usual 3000 rpm in ordinary direct driven compressors
- Utilizing an over-sized air-end, resulting in:
 - Lower rotation frequency
 - Lower noise level
 - Considerably less depreciation

ROTARY SCREW AIR COMPRESSORS (OIL INJECTED)

ATV SERIES

Variable Speed Drive (VSD)

ATV-Series of our compressors incorporate the latest advancements in variable speed drive (VSD) technology to increase air flow output by up to 15 percent, reduce energy costs by up to 35 percent and increase system reliability. Reducing costs while improving productivity and energy efficiency is the prime goal in ATV series to create an exemplary compressor efficiency plus durability in order to keep your plants running optimally.

Main Features:

- 15 kW to 450 kW
- Maximum efficiency
- Variable Speed
- Maximum protection for electric motors
- Air production in proportion to consumption
- Air-Cooled & Water-Cooled types
- Flange-Mounted Motor and Air End
- Premium Efficient SIEMENS Motor
- Microprocessor Controller



Model	Flow (m3/min)	Power (KW)	Motor speed (RPM)	Noise (dB)	Connection (inch)	Dimensions (mm)			Weight (kg)
	5 – 13 barg					L	W	H	
ATV15	1.3 - 3.4	15	3000	78	1"	1200	1100	1400	600
ATV22	2.4 - 4.7	22	3000	78	1"	1200	1100	1400	800
ATV30	3.4 - 5.8	30	3000	78	1 1/2"	1800	1300	1600	1050
ATV37	4.5 - 6.9	37	3000	78	1 1/2"	1800	1300	1600	1100
ATV45	5.6 - 8.6	45	3000	78	1 1/2"	1800	1300	1600	1350
ATV55	7 - 11.5	55	3000	78	1 1/2"	1800	1300	1600	1550
ATV75	9.5 - 15	75	3000	78	2"	3000	1700	2100	2250
ATV90	11.5 - 15.5	90	3000	78	2"	3000	1700	2100	2900
ATV110	12.5 - 21.5	110	3000	78	2"	3000	1700	2100	2950
ATV132	16.5 - 29	132	3000	78	3"	3000	1700	2100	3250
ATV160	19.5 - 28	160	3000	78	3"	3000	1700	2100	3960
ATV200	26 - 43	200	3000	78	4"	3500	2000	2100	4550
ATV250	30 - 54	250	3000	78	4"	3500	2000	2100	5950
ATV315	41 - 54	315	3000	78	4"	4100	2100	2100	6100
ATV355	46 - 54	355	3000	78	4"	4100	2100	2200	6200
ATV450	55 - 72	450	3000	78	4"	4100	2100	2200	8500



ROTARY SCREW AIR COMPRESSORS (OIL INJECTED)

ATB SERIES

Belt Driven

Belt driven rotary screw air compressors “ATB Series” provide you with the industry’s most reliable belt drive air compressor on the market. Deciding between a direct or belt driven compressors depends on your primary concerns; if you need to adjust speed and power, then a belt driven compressor will be the better option for you. As long as it is properly lubricated, a belt drive compressor will run more smoothly and therefore quieter. That makes it a good choice for environments in which noise levels matter.

Main Features:

- 15 kW to 160 kW
- Economic performance
- Low capital investment costs
- Higher Variable Capacity
- Highly Maintenance friendly
- Microprocessor Controller
- Lower Noise level 76 (dB)



Compact
(ATC 11/15/18)

Model	Flow (m3/min)			Power (kw)	Motor speed (RPM)	Noise (dB)	Connection (inch)	Dimensions (mm)			Weight (kg)
	8 bar g	10 bar g	13 bar g					L	W	H	
ATB 15	2.5	2	1.3	15	3000	76	1"	1200	1100	1400	435
ATB 18.5	3.3	2.6	2	18.5	3000	76	1"	1200	1100	1400	450
ATB 22	3.8	3.3	2.6	22	3000	76	1"	1200	1100	1400	485
ATB 30	4.8	4.3	4.3	30	3000	76	1 1/2"	1800	1300	1600	1060
ATB 37	5.8	4.7	4.5	37	3000	76	1 1/2"	1800	1300	1600	1100
ATB 45	7.2	6.9	5.5	45	3000	76	1 1/2"	1800	1300	1600	1400
ATB 55	8.9	7.8	6.7	55	3000	76	1 1/2"	1800	1300	1600	1600
ATB 75	12.7	11.3	9.2	75	3000	76	2"	3000	1700	2100	1850
ATB 90	14.5	13.2	11.4	90	3000	76	2"	3000	1700	2100	2600
ATB 110	19	16.8	13.8	110	3000	76	2"	3000	1700	2100	2650
ATB 132	22	18.5	16.3	132	3000	76	3"	3000	1700	2100	3150
ATB 160	26.5	23.5	19.7	160	3000	76	3"	3000	1700	2100	3320

POSITIVE DISPLACEMENT AIR BLOWERS (OIL FREE)

ATBL Series

Belt Driven

AIRTRUST Positive Displacement Blowers (ATBL Series) are designed to optimize the reliability and efficiency of your low pressure applications. Our blowers deliver 0.5 – 250 m3/min class 0 certified oil-free air to different industrial sectors such as Waste Water Treatment, Bulk Transmission, Chemical and Process Technology, Power Plants, Cement, Foodstuffs, Paper,...

Main Features:

- 1.5 Kw to 500 Kw
- Pressure: 0.3 – 1 bar
- Oil-Free Class 0 (ISO 8573-1)
- Energy-Efficient Design
- 3-Lobe Rotor Design
- Heavy duty design for reduced downtime
- Quiet operation



Model	Flow m3/min	Delta Pressurebar	Power Kw
ATBL – GM3S	0.58 – 4.12	300 - 900	1.5 - 11
ATBL – GM4S	0.79 – 5.71	300 - 1000	2.2 - 15
ATBL – GM7L	1.24 – 5.89	300 - 700	2.2 - 15
ATBL – GM10S	2.13 – 12.1	300 - 1000	3.1 - 30
ATBL – GM15L	3.23 – 17.9	300 - 700	4.1 - 30
ATBL – GM25S	5.05 - 21	300 - 1000	5.5 - 55
ATBL – GM30L	7.34 – 35.4	300 - 700	7.5 - 75
ATBL – GM35S	11.7 – 40.3	300 - 1000	11.1 - 90
ATBL – GM50L	17.7 – 55.4	300 - 700	15 - 90
ATBL – GM60S	13.3 – 59.4	300 - 1000	15 - 132
ATBL – GM80L	19.3 – 85.2	300 - 700	18.5 - 160
ATBL – GM90S	29.1 – 90.3	300 - 1000	30 - 200
ATBL – GM130L	43.5 - 134	300 - 600	37 - 200
ATBL – GM150S	68.4 - 152	300 - 1000	55 - 355
ATBL – GM220L	96.8 - 227	300 - 600	75 - 355
ATBL – GM240S	100 - 246	300 - 800	90 - 500

LIQUID RING COMPRESSOR / VACCUM (ATLR Series)

1600-5000 m³/hr @ 2.2 Bar compressed discharge / 60 mbar Suction

ATLR machines are vacuum pumps and compressors which are designed and manufactured by AIRTRUST for the compression of gases and vapours. They are used for those duties in the field of process technology which would otherwise be uneconomical, unsafe or impossible to carry out. These machines compress the gases or gas vapour mixtures generated in various processes from the "suction pressure" to the "discharge pressure". In vacuum pumping application, the suction pressure is lower than atmospheric, whereas the discharge pressure with compressors application is higher than atmospheric.

Main Features:

- ▶ Single Stage function
- ▶ Steel / Cast Iron Impeller
- ▶ Fully Steel Construction (option)
- ▶ Belt Driven
- ▶ Discharge: ≤ 2.2 bar
- ▶ Suction: ≤ 60 mbar



Model	M ³ /h	Discharge Flow Pressure (bar)	Suction Flow Pressure (mbar)	Motor Power (kW)
ATLR - 1600	1600	2.2	60 - 100	45 - 55
ATLR - 3000	3000	2.2	60 - 100	90 - 110
ATLR - 4200	4200	2.2	60 - 100	110 - 132
ATLR - 5000	5000	2.2	60 - 100	132 - 160

**PARTS &
COMPONENTS**
ORIGINAL / OEM

GENUINE PARTS & CONSUMABLES

Rotary Screw Air Compressors

Original Equipment Manufacturers' Parts (OEM)

Keeping up with preventative maintenance is a vital part of maintaining a compressor's efficiency and lifespan. This requires periodic replacement of air compressor parts.

Using genuine air compressor maintenance replacement parts can be initially a more expensive option, but by using genuine parts, in the long run you will reduce your air compressor maintenance costs, machinery down time by avoiding future hiccups or part replacement.



COMPRESSOR OIL (ROTO OIL)

Premume Lubricant "68" For Air Compressors

ROTO Oil is uniquely tailor-designed to provide long service life in most compressor applications. The thermal stability and oxidation resistance of ROTO OIL can help to maintain cleaner compressors, thereby enabling longer running periods between scheduled maintenance and oil

Main Benefits:

- ▶ High resistance to oxidation and thermal degradation
- ▶ Potent anti-wear & anti-clogging protection
- ▶ Excellent rust and corrosion protection
- ▶ Rapid release of foam and air release control
- ▶ Rapid water separation from the oil
- ▶ Provide low temperature fluidity protection



ISO Viscosity Grade "68" (1000 / 2000 Hr)			
Test Parameters	ASTM	Values	Values
Viscosity @ 40 °C, cSt	D 445	61.02	58
Viscosity @100°C, cSt	D 445	8.88	9.24
Viscosity Index	D 2270	100	120
Flash Point, °C	D 92	220	240
Pour Point, °C	D 97	-15	-25
Density @ 15°C, Kg/l	D 1298	0.885	0.885
Conradson Carbon Residue(CCR), %m	D 189	0.5	0.5
Demulsibility @54°C	D 1401	Pass	Pass
Total Acid number, mg KOH/g	D 974	Pass	0.15
Oxidation Stability (RBOT)	D 2272	1500 H	3000 H

ZEOLITES and CMS

Molecular Sieves, Carbon Molecular Sieves etc.

Molecular sieve will adsorb most molecules with a kinetic diameter of less than 3-4 angstroms and exclude those larger. Such adsorb-able molecules include simple gas molecules such as oxygen, nitrogen, carbon dioxide and straight chain hydrocarbons.

Types:

Type	Description
3A	K-Na Zeolite A with a nominal pore opening of 3 Å (0.3 nm)
4A	Na zeolite A with a nominal pore opening of 4 Å (0.4 nm)
5A	Ca-Na Zeolite A with a nominal pore opening of 5 Å (0.5 nm)
13X	Na zeolite X with a nominal pore opening of 10 Å (1.0 nm)



ATM 300-1300

Molecular Sieve (3A/4A/13X Properties)

Model	ATM-300 (3A)		ATM-400 (4A)		ATM-1300 (13X*)	
Color	Light Grey					
Shape	Sphere					
Diameter (mm)	1.7-2.5	3.0-5.0	1.7-2.5	3.0-5.0	1.7-2.5	3.0-5.0
Size ratio up to grade (%)	≥98	≥98	≥98	≥98	≥98	≥98
Bulk density (g/ml)	≥0.72	≥0.70	≥0.70	≥0.70	≥0.67	≥0.65
Wear ratio (%)	≤0.20	≤0.20	≤0.20	≤0.20	≤0.20	≤0.20
Crushing strength (N)	≥35	≥85	≥35	≥85	≥25	≥75
Static H2O adsorption (%)	≥22	≥22	≥21	≥21	≥27	≥27
Water content (%)	≤1.0	≤1.0	≤1.5	≤1.5	≤1.5	≤1.5

To remove moisture from ATM-13X molecular sieve, a temperature of 250-300°C is required. A properly regenerated molecular sieve can give moisture dew points below -100°C or CO2 levels below 2ppm.

ATC-200

Carbon Molecular Sieve

CMS is the crucial element of any PSA-Plant for the generation of Nitrogen. With their well-defined pore size, AIRTRUST ATC-200 high selectivity CMS is used as adsorbents for high performance PSA systems.



TYPE	Adsorbent Pressure (MPa)	N2 Purity (N2%)	N2 Quantity (NM3/h.t)	N2/Air (%)	Model	ATC-200
ATC-200	0.8	99.99	70	21	Color	Black
		99.9	140	27	Shape	Pellet / Extruded
		99.5	200	36	Diameter (mm)	1.1-1.3
		99	260	41	Dust level	100 PPM
		98	330	48	Bulk density (g/ml)	1. 650-690 g/l
				Crushing strength (N)	40 N/P	
				Switch Cycle	650-690 g/l	

AIRTRUST System planner for compressed air preparation - purity classes for compressed air

A compressor sucks in this amount of impurities at 1000 m³/h per day:
 approx. 333 L water (humidity at 25 ° C, 60% r.F.)
 approx. 1 billion solids > 2 μm
 approx. 3500 billion solids < 2 μm
 approx. 2 to 3 g of oil vapors

ISO 8573-1:2010

Oil Injected Compressor



Oil Free Compressor

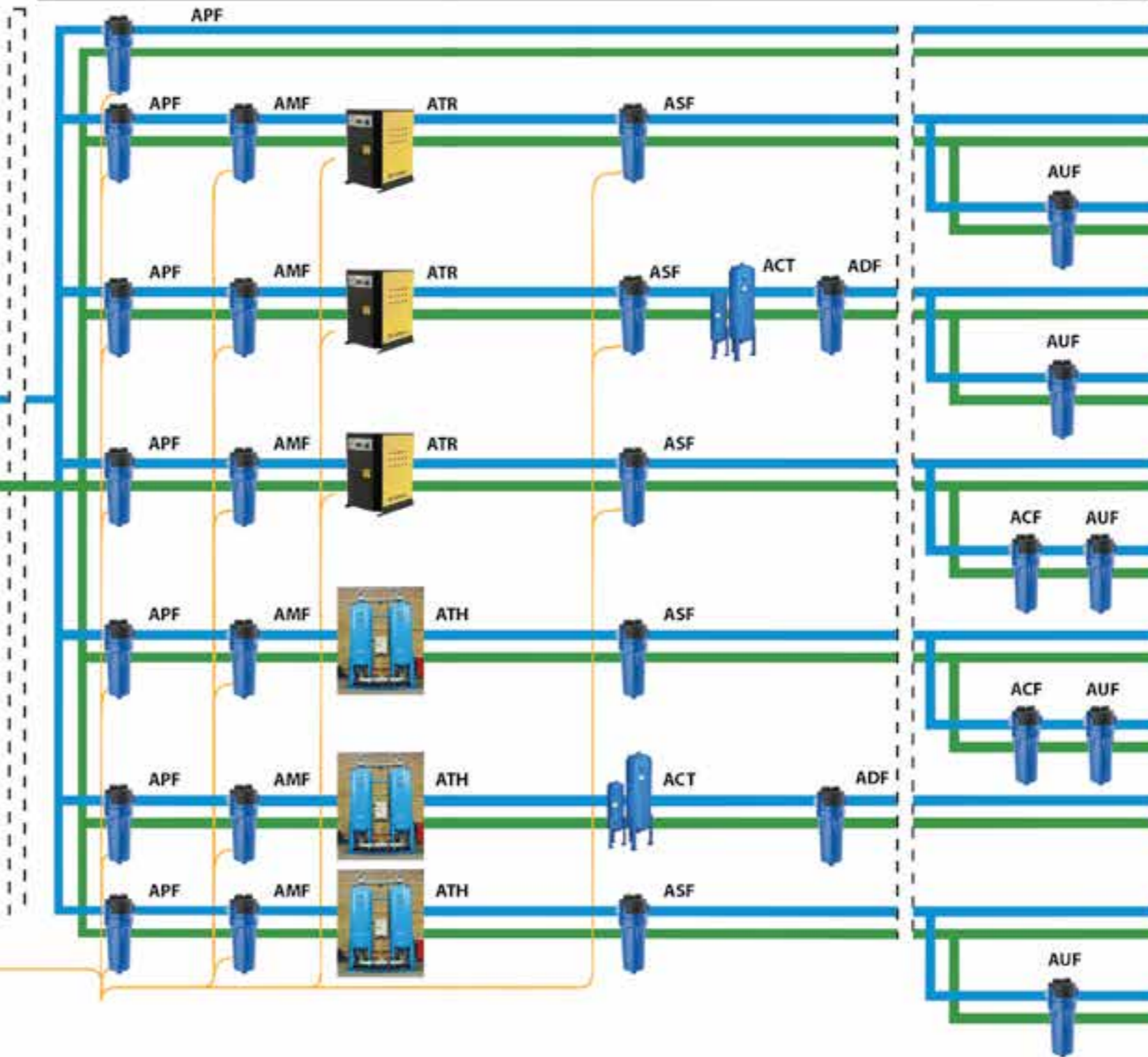

ISO 8573-1:2010

CLASS	Solid particles - Max. number / m ³			Pressure dew point °C	Oil Content in mg/ m ³
	0,1 - 0,5 μm	0,5 - 1 μm	1 - 5 μm		
0	To be agreed with operator (better than class 1)				
1	≤ 20.000	≤ 400	≤ 10	≤ -70	≤ 0,01
2	< 400.000	≤ 6.000	≤ 100	≤ -40	≤ 01
3	n. v.	≤ 90.000	≤ 1000	≤ -20	≤ 1
4	n. v.	n. v.	≤ 10.000	≤ +3	≤ 5
5	n. v.	n. v.	≤ 100.000	≤ +7	N.A

Reference conditions 1 bar(a), 20 ° C, 0% relative humidity;
 Pressure dew point at final compressor pressure 8 bar(a)

Particles	Water & Humidity	Total Oil
-	7-8	-
2	4-6	2
1	4-6	2
2	4-6	1
1	4-6	1
2	1-4	2
1	1-4	1
2	1-2	2
1	1-2	1
2	1-2	1
2	1-2	1
1	1-2	1

WS
Water Separator

ATH
Dessicant Dryer
Dew point: -40/-70°C

For removal of oil content down to 0.003 mg/m

ACT
Activated Carbon Tower

Dew point: +3°C

ATR
Refrigeration Dryer

3μ	APF	Air Pre Filter
1μ - 0.01 mg/m ³	AMF	Air Main Filter
1μ - 0.01 mg/m ³	ASF	Air Second Filter
1μ - 0.01 mg/m ³	ADF	Air Dust Filter
0.001 μ	AUF	Air Ultra Filter
0.003 mg/m ³	ACF	Air Carbon Filter

AIR
TREATMENT



AIR/GAS DRYERS

Desiccant Adsorption

ATH SERIES

Heatless Type

Dryers help preventing pipework corrosion, product spoilage and premature failure of pneumatic equipment. Properly treated compressed air, and the right air/gas dryer, will improve productivity, system efficiency, and product or process quality (DIN ISO 8573-1).

By choosing AIRTRUST Heatless dryers (ATH series) with outlet pressure dew point of up to -70°C, you are buying high quality treatment products that will enhance your entire air compressor system.

Main Features:

- Capacities 2 – 154 m3/min
- Regeneration air/gas consumption rate:~15%
- Globally certified desiccant material
- Highly smart controlling system
- Lower capital investment
- Equipped with dew point sensor on outlet flow (option)
- Vessels fabrication based on ASME



MODEL	M3/Min	L	W	H	DN	Kg	KW
ATH-20	2	850	550	1900	20	145	0.25
ATH-30	3	1020	550	1900	25	180	0.25
ATH-40	4	1050	550	2210	25	210	0.25
ATH-50	5	1100	650	2510	25	250	0.25
ATH-60	6	1140	750	2100	40	230	0.25
ATH-70	7	1320	800	2240	40	370	0.25
ATH-100	10	1420	850	2510	40	430	0.25
ATH-150	15.2	1420	850	2510	40	510	0.25
ATH-170	17	1500	850	2680	80	730	0.25
ATH-200	20	1800	850	2630	80	780	0.25
ATH-300	30.5	2020	1040	2680	80	880	0.25
ATH-500	50.5	1950	1040	2950	100	1500	0.25
ATH-600	60.8	1950	1040	3100	100	1990	0.25
ATH-800	80.5	1950	1040	3300	100	2400	0.25
ATH-1000	101	1950	1040	3400	100	3050	0.25
ATH-1200	122.6	1950	1140	3450	100	3150	0.25
ATH-1500	154.4	2100	1250	3500	125	3500	0.25

AIR/GAS DRYERS

Desiccant Adsorption

ATE SERIES

Heated Type

Compressed air is polluted with dirt particles, water, oil, oil vapor, and condensate. These contaminants result in high maintenance costs, premature wear, spoiled products and the failure of control systems. AIRTRUST heated desiccant dryers (ATE Series) will effectively remove contaminants such as dirt, water, and oil. The traditional adsorption principle used in this design is simple, robust and flexible. Continuous drying is accomplished by the operation of two desiccant towers.

Main Features:

- Capacities from 10 – 251 m3/min
- Regeneration air/gas consumption rate:~4%
- Globally certified desiccant material
- Lower operating costs
- Highly smart controlling system
- Equipped with dew point sensor on outlet flow(option)
- Vessels fabrication based on ASME
- Insulated tower, heater and purge lines increase dryer performance and efficiency by reducing radiant heat loss



MODEL	M3/Min	L	W	H	DN	Kg	KW
ATE-100	10	1300	1400	2500	40	1250	6
ATE-150	15.2	1500	1350	2500	40	1470	12
ATE-170	17	1700	1400	2600	80	1690	14
ATE-200	20	1800	1350	2630	80	2010	22
ATE-300	30.5	1830	1620	2860	80	3250	25
ATE-500	50.5	2100	1680	3000	100	3450	30
ATE-600	60.8	2300	1800	3200	100	4200	33
ATE-900	90.6	2700	2500	3500	150	5100	55
ATE-1000	101	2700	2500	3500	150	5480	60
ATE-1200	122.6	2700	2500	3600	150	6740	72
ATE-1500	154.4	3000	3000	3800	200	8520	84
ATE-1750	175.5	3200	3000	3800	200	10540	102
ATE-2000	203.2	3200	3000	4000	200	12700	120
ATE-2500	251.2	3500	3500	4200	250	15820	150

AIR DRYERS

Refrigerant Type

ATR Series

Refrigerant Air Dryers help you to achieve maximum energy savings, while ensuring a continuous supply of dry, high-quality compressed air. AIRTRUST offers a European brand specially manufactured & designed to help optimal and strong performance with a steady pressure dew point with no risk of moisture entering your compressed air system. wherever it may be utilized in Iran territory.

Main Features:

- Steady pressure dew point (+2°C to +5°C)
- Operating ambient temp. (1.5°C to 45°C)
- Evaporator (brazed plate S.S / Aluminum)
- Max. operating pressure up to 16 bar
- Compressor (Emerson/Copeland/Tecumseh)
- Electronic drain or programmable timer
- Easy installation / maintenance
- Reduced energy consumption
- IP 55 protection class



MODEL	M3/Min	L(mm)	W (mm)	H (mm)	DN	Kg	W
ATR-20	0.33	485	352	499	G 3/8" BSP-F	25	135
ATR-35	0.58	485	352	499	G 3/8" BSP-F	25	135
ATR-50	0.83	485	352	499	G 3/4" BSP-F	26	180
ATR-75	1.25	485	352	499	G 3/4" BSP-F	27	250
ATR-100	1.67	485	352	499	G 3/4" BSP-F	32	320
ATR-140	2.33	552	357	684	G 1" BSP-F	50	480
ATR-180	3.00	552	357	684	G 1" BSP-F	52	500
ATR-235	3.92	552	357	684	G 1" BSP-F	56	700
ATR-300	5.00	589	496	827	G 1 1/4" BSP-F	84	950
ATR-380	6.33	589	496	827	G 1 1/4" BSP-F	90	1.080
ATR-480	8.00	589	496	827	G 1 1/2" BSP-F	99	1.200
ATR-600	10.00	710	491	973	G 2" BSP-F	110	1.250
ATR-750	12.50	710	491	973	G 2" BSP-F	120	1.600
ATR-950	15.83	710	491	973	G 2" BSP-F	150	2.100
ATR-1150	19.17	856	663	1.534	G 2 1/2" BSP-F	250	2.200
ATR-1300	21.67	856	663	1.534	G 2 1/2" BSP-F	280	2.600
ATR-1500	25.00	856	663	1.534	G 2 1/2" BSP-F	290	2.700
ATR-1900	31.67	856	663	1.534	G 2 1/2" BSP-F	310	4.000

* Bigger sizes available up to ATR-13200 (220 M3/min)

RECIEVER TANKS

COMPRESSED AIR/GAS

AIRTRUST produce a wide range of air receiver tanks according to ASME SEC VIII from 500 to 50,000 litres at 7-40 bar. These receiver tanks are used in compressed air systems to store compressed air/gas and permit pressure to be equalized in the system. All tanks go through RT-UT and HYDRO tests and related reports and documents will accompany deliveries. Tanks with stainless steel material and pressure up to 60 bar are also in production range.



Main Features:

- SAW welding vessels
- Manholes, Pressure Gauge, PSV, Auto-drain valves
- Anti-Corrosive primers, Epoxy, Zinc-rich coatings
- Hydrostatic test Procedure, Painting test Procedure
- Internal & external galvanization ISO 1461 (option)

MODEL	A (mm)	B (mm)	C (mm)	D (mm)
AR 500	630	2100	700	1600
AR 1000	840	2100	700	1600
AR 2000	1060	2715	950	2150
AR 3000	1060	3735	950	3100
AR 4000	1400	3075	1000	2500
AR 5000	1400	3825	1000	3200
AR 6000	1400	4335	1000	3800
AR 8000	1580	4655	1050	3900
AR 10000	1750	4655	1050	3900
AR 15000	2000	8200	1200	4200
AR 20000	2300	8200	1200	5000
AR 30000	2500	9000	1200	4500
AR 50000	2800	9400	1200	6400

COMPRESSED AIR TREATMENT ACCESSORIES

MICRO FILTRATION

(AFT Premium Filter Elements)

AIRTRUST filters (AFT Series) are designed and manufactured in Europe for protection of the downstream compressed air system and equipment against defects and other failures. They ensure high efficient removal of solid particles, water, oil aerosols, hydrocarbons, odour and vapours from compressed air systems up to 16 bar in order to achieve air quality according to standard ISO 8571-1.

Main Features:

- Plastic endcaps (Ultramid polyamide)
- Better temperature performance
- Up to 6 wrapped layers for fine filtration
- High quality drainage foam
- Stainless steel expanded mesh support

Characteristics:

- Operating pressure: 16 bar
- Volume flow rate: 72 – 9000 Nm3/h
- Connections: 3/8"-8"
- Operating temp. range: 1.5-65°C

MATERIAL	
Housing material	Aluminium / Carbon Steel SA-516-Gr 70
Fittings, Screws	Brass, Brass-zinc plated, Steel
Cover	PA6
Sealing	NBR
Corrosion protection	Anodized (optional)
Outside protection	Powder paint coated (Epoxy-polyester)



WATER-OIL SEPARATORS

AWS Series

During the compression process, outside contaminants such as water vapor and dust are mixed in with the hot oil. Once the air has cooled down at the end of the compression process, contaminated condensate is generated. AWS Separators have been developed to separate oil from condensate of compressed air systems.

Characteristics:

- Operating temp. range: 16 bar
- Volume flow rate: 72 – 9000 Nm3/h
- Connections: 3/8"-8"
- Operating temp. range: 1.5-65°C

MODEL	Flow Rate (m3/h)	Port Size (Inch - DN)	Max Pressure (bar g)
AWS 20	120	G 1	16
AWS 30	180	G 1	16
AWS 40	240	F 1 ½	16
AWS 50	300	F 1 ½	16
AWS 60	360	F 1 ½	16
AWS 70	420	F 2	16
AWS 80	480	F 2	16
AWS 100	600	F3	16
AWS 200	1200	F 3	16
AWS 250	1500	F 3	16
AWS 300	1800	F 4	16
AWS 400	2400	F 4	16
AWS 500	3000	F 6	16
AWS 700	4200	F 6	16



* Bigger sizes available on request

Pressure (bar)	1 bar	3 bar	5 bar	7 bar	10 bar	13 bar	14 bar	15 bar	16 bar
Correction Factors	0.3	0.5	0.8	1	1.3	1.5	1.6	1.7	1.90

Sizing example

Actual Flow/Factor = 150 / 1.3 = 115.3 m3/h Select: ATWS 200	Actual Flow	150 m3/h
	Min. Pressure	10 bar g
	Max. Inlet Temp.	50°C
	Factor from Table	1.3

ACTIVED CARBON TOWER

ACT Series 20-1000

Activated Carbon adsorber is designed to ensure oil and odorless compressed air. Compressed air is passed through a bed of activated charcoal and ensures a residual oil content in the compressed air of <0.003 ppm. The remaining oil content in the compressed air depends on the inlet.

Model	Flow Rate (m3/h)	Port Size (Inch - DN)	Max Pressure (bar g)	Max Temp. (°C)
ACT20	120	G 1	16	50
ACT30	180	G 1	16	50
ACT40	240	G 1	16	50
ACT50	300	G 1	16	50
ACT60	360	G 1 ½	16	50
ACT70	420	G 1 ½	16	50
ACT100	600	G 1 ½	16	50
ACT120	720	G 2	16	50
ACT150	900	DN50	16	50
ACT170	1020	DN65	16	50
ACT200	1200	DN65	16	50
ACT220	1320	DN80	16	50
ACT250	1500	DN80	16	50
ACT350	2100	DN100	16	50
ACT400	2400	DN125	16	50
ACT500	3000	DN125	16	50
ACT700	4200	DN125	16	50
ACT900	5400	DN150	16	50
ACT1000	6000	DN150	16	50



OPERATING RANGE	
Ambient Temperature	5-40 °C
Max. Compressed Air Inlet Temp.	50 °C
Max. Operation Pressure	16 bar g
Medium	Air and Gas

INDUSTRIAL UTILITY PIPING SYSTEM

Compressed Air/Gas

AIRTRUST piping team is committed to being your premier utility piping contractor with wide knowledge and expertise in design and execution of your piping system with international standards like API, ASME, ANSI, ISO, DIN etc.

We design, procure and execute the compressors, air manager system with automation and distribution pipeline networks for the complete system including filters, air dryers and receiver units, etc. The primary object of a compressed air distribution system is to transport the compressed air from its point of production (compressors) to its points of use (applications) providing compressed air:

in sufficient quantity, at the required pressure, in the necessary quality, with the smallest possible drop in pressure, safely and cheaply

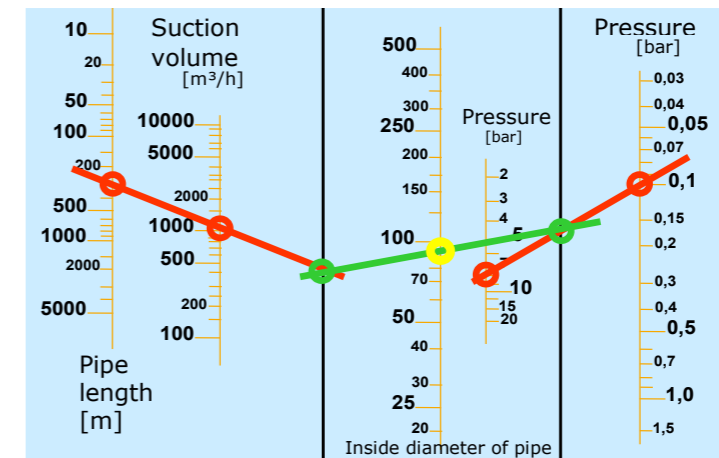

Diameter of hole[mm]	Air loss at 6 bar [l/s]	Air loss at 2 bar [l/s]	Energy loss at 6 bar [kWh]	Energy loss at 12 bar [kWh]	Costs at 6 bar [Euro]	Costs at 12 bar [Euro]
1	1,2	1,8	0,3	1,0	240	800
3	11,1	20,8	3,1	12,7	2.480	10.160
5	30,9	58,5	8,3	33,7	6.640	26.960
10	123,8	235,2	33,0	132,0	26.400	105.600



**OIL FREE
COMPRESSED
AIR**

ALMIG
Compressor Systems

ROTARY SCREW AIR COMPRESSORS (OIL FREE)

LENTO SERIES

Direct Drive - Water Injected

Oil-free LENTO series of ALMiG Kompressoren GmbH deliver maximum cost-effectiveness in compressed air treatment by precisely matching the volume flow to the exact "CLASS 0" compressed air requirement and through low compressed air outlet temperatures and minimized service and maintenance costs.

Main Features:

- Compressor
 - Single-stage, water-injected
 - Low final compression temperatures (<60°C)
- SCD motor
 - IP 55 ISO F protection class
 - Compact / High-performance / Reliable
- Integrated refrigeration dryer with 3 jobs:
 - Producing fresh water for generating the coolant
 - Ensuring optimum biological water quality
 - Delivering dry compressed air at the inlet
- Water circuit
 - Closed water circuit, integrated water treatment
 - Multi-stage separation for dry compressed air
- Direct drive
 - Zero-loss power transfer
- SCD frequency converter
 - The integrated power pack; acc. to EMC guidelines
- Air Control P
 - The compressors' intelligence; thinks, monitors and records



Not only is there demand for high-quality, 100% oil-free compressed air in the pharmaceutical, food-stuffs, electrical engineering and medical industries, but wherever products of the highest quality are produced. Only water, the most natural of all raw materials, is used in the compression process of LENTO Series.

50 Hz speed-controlled							
LENTO	Operating over-pressure	Volume flow acc. to ISO 121 (Annex C-2009)		Rated Motor Power	Length	Width	Height
		min. (m³/min)	max. (m³/min)				
	bar			KW	mm	mm	mm
15	5-10	1.01	2.34	15	1880	850	1660
18	5-10	1.01	2.87	18.5	1880	850	1660
22	5-10	1.01	3.38	22	1880	850	1660
30	5-10	1.01	4.30	30	1880	850	1660
31	5-10	2.04	5.08	30	2300	1400	1560
37	5-10	2.04	6.14	37	2300	1400	1560
45	5-10	2.04	7.13	45	2300	1400	1560
55	5-10	2.04	8.19	55	2300	1400	1560
46	5-10	2.49	8.18	45	2674	1769	1400
56	5-10	2.49	9.86	55	2674	1769	1400
75	5-10	2.49	12.46	75	2674	1769	1400
76	5-10	4.06	13.82	75	3448	1500	1927
90	5-10	4.06	16.43	90	3448	1500	1927
110	5-10	4.06	19.60	110	3448	1500	1927

From 15 to 75 kW (Air Cooled & Water Cooled)
From 90 to 110 kW (only Water Cooled)

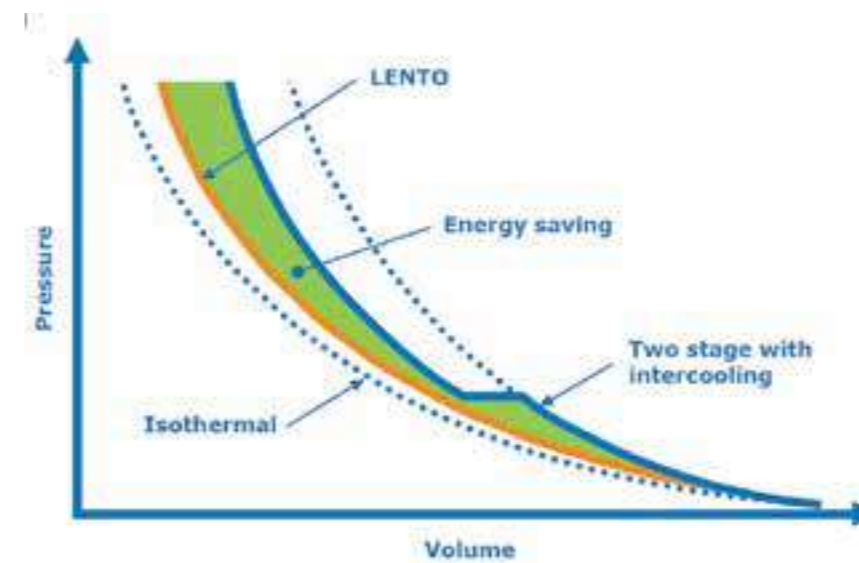

ROTARY SCREW AIR COMPRESSORS (OIL FREE)

SIMPLEXX SERIES

DIRECT DRIVE – DOUBLE STAGE -WATER INJECTED



With SIMPLEXX series, ALMiG has expanded its oil-free range with a two-stage compressor that supplies customers with 100% oil-free compressed air at low operating costs. A well-thought-out design of the machine using high-quality materials to achieve a noise level that is market leading in the field of two-stage oil-free technology. This series is also equipped with a control system which continuously monitors all important parameters, thus ensuring efficient operation and offering the customer additional options such as regulating the operation of several compressors in one station.

Main Features:

- Two-Stage dry screw technology
- Guaranteed 100% oil-free air
- Fix speed & speed controlled
- Initial range from 110 – 450 kW
- Market leading sound level
- Air & Water Cooling
- Air Control, HE controller as standard



Made in Germany



SIMPLEXX series is offered with fixed speed as well as speed-controlled version and covers a volume flow requirement of 10 - 29 m³/min. The compressors are offered both with air cooling and optionally with water cooling.

SIMPLEXX 50 Hz								
SIMPLEXX	Volume flow in accordance with ISO 1217 (annex C-1996)			Rated motor power	Length	Width	Height	weight
	bar 7.5	bar 8.5	bar 10.5					
	m3/min	m3/min	m3/min	kW	mm	mm	mm	kg
110	20.11	18.88	16.52	110	3.140	1.720	1.800	3.600
132	23.77	22.32	20.04	132	3.140	1.720	1.800	3.650
160	27.07	27.03	23.68	160	3.140	1.720	1.800	3.700
200	38.57	35.98	33.42	200	3.800	2.000	2.000	4.150
250	46.80	46.77	38.45	250	3.800	2.000	2.000	4.250
315	58.02	57.92	46.73	315	4.500	2.250	2.250	8.000
400	68.06	68.52	57.74	400	4.500	2.250	2.250	8.100
450	88.48	79.38	68.34	450	4.500	2.250	2.250	8.200

SIMPLEXX 110-160 also available as air-cooled version, dimensions refer to water-cooled version

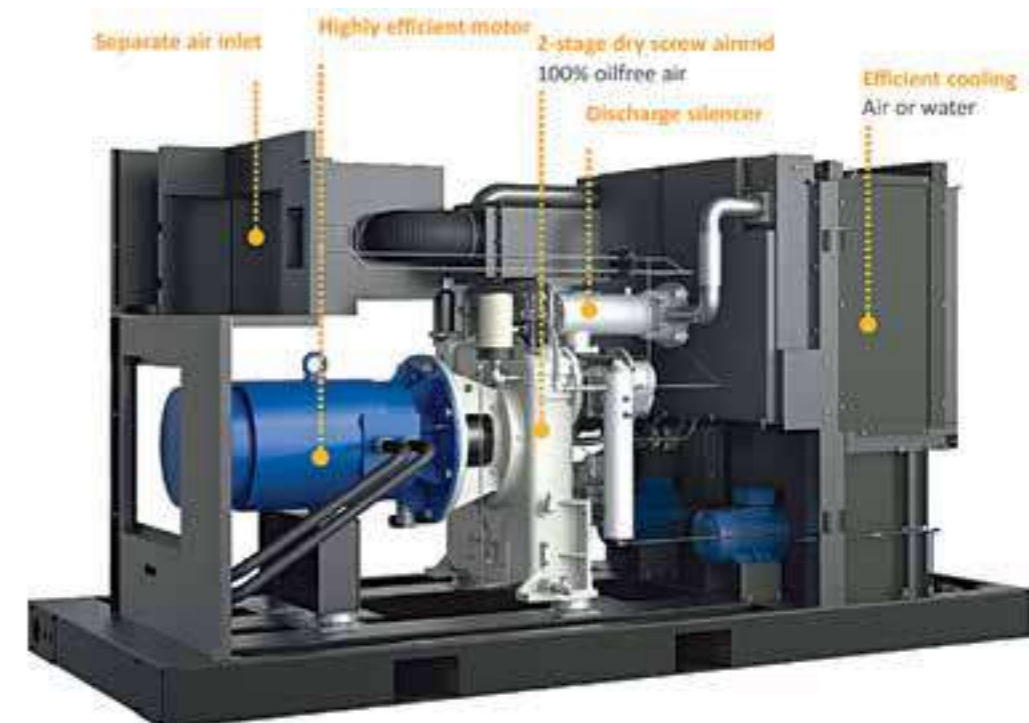

AIR SEPARATION
*NITROGEN &
OXYGEN PRODUCTION*



NITROGEN GENERATORS PSA MODULAR

Up to 99,999% Nitrogen / 150 Nm3/h

Modular PSA generators implement a unique Pressure Swing Adsorption technology and can produce nitrogen purity of up to 99.999% with pressure up to 8.5 bar (standard range) plus customized versions of up to 11 bar.

Unlike twin-tower standard systems, modular generators feature multiple modules of molecular sieve, each implementing an optimized patented PSA process.

Main Features:

- Outlet Flow: 5 to 150 Nm3/h
- Residual oxygen: 10 ppm to 3.0 vol.%
- Discharge Pressure: up to 8.5 bar (Customized Ver. up to 11 bar)
- SIEMENS SIMATIC PLC, Graphic Touch Panel HMI
- Unlimited Flexibility: production capacity can be easily adjusted without any skilled personnel
- Compact Dimensions
- Non-corrosive materials used for all process components
- Easy fleet management: limited spare part management and easy maintenance



SIEMENS SIMATIC HMI

Allows monitoring / control of main process parameters, displays gas purity, flow rates, totalized gas flow, functioning hours, maintenance alerts etc.

Model	Flow (m3/h)					Pressure (bar)	Dimension			Weight (kg)				
	10 ppm	50 ppm	100 ppm	500 ppm	0.10%		0.50%	1%	2%		3%	L(mm)	W(mm)	H(mm)
NS-7	2.2	2.9	3.5	4.8	5.7	8.3	10	12.2	13.1	7	520	830	1422	256
	2.6	3.5	4.2	5.9	7	10.1	11.6	14.3	15.4	10				
NS-14	4.4	5.8	7	9.6	11.4	16.5	19.8	24.3	26.1	7	520	955	1422	366
	5.2	7	8.3	11.8	14	20.1	23	28.4	30.7	10				
NS-21	6.6	8.7	10.5	14.4	17	24.6	29.6	36.3	39	7	520	1183	1422	476
	7.8	10.4	12.4	17.7	20.9	30	34.3	42.5	45.9	10				
NS-28	8.7	11.5	13.9	19.1	22.5	32.7	39.3	48.1	51.8	7	520	1141	1422	586
	10.4	13.8	16.5	24.6	28.2	39.8	45.6	56.4	60.9	10				
NS-37	10.9	14.4	17.3	23.8	28.1	40.7	48.9	59.9	64.5	7	520	1639	1422	696
	12.9	17.2	21.5	30.6	35	49.5	56.7	70.1	75.7	10				
NS-42	13	17.2	20.7	29.4	34.5	48.6	58.4	71.5	77	7	520	1867	1422	806
	15.4	20.6	25.6	36.6	41.9	59.1	67.8	83.8	90.5	10				
NS-49	15.1	20.1	24.3	33	38.9	56.4	67.8	83.1	89.4	7	520	2095	1422	916
	17.9	23.9	29.8	42.5	48.6	68.7	78.7	97.3	105.1	10				
ND-56	17.2	22.9	27.7	37.5	44.3	64.2	77.1	94.5	101.7	7	520	2323	1422	1026
	20.3	27.2	33.9	48.3	55.3	78.1	89.5	110.7	119.5	10				
NS-74*	21.8	28.8	34.6	47.6	56.2	81.4	97.8	119.8	129	7				
	25.8	34.4	43	61.2	70	99	113.4	140.2	151.4	10				
NS-84*	26	34.3	41.4	58.8	69	97.2	116.8	143	154	7				
	30.8	41.2	51.2	73.2	83.8	118.2	135.6	167.6	181	10				
NS-98*	30.2	40.2	48.6	66	77.8	112.8	135.6	166.2	178.8	7				
	35.8	47.8	59.6	85	97.2	137.4	157.4	194.6	210.2	10				
NS-112*	34.4	45.8	55.4	75	88.6	128.4	154.2	189	203	7				
	40.6	54.4	67.8	96.6	110.6	156.2	179	221.4	239	10				



NITROGEN GENERATOR PSA TWIN-TOWER

Up to 99,999% Nitrogen / 1.500 Nm3/h



Compared to Modular PSA Nitrogen Generators, the Twin-Tower PSA Nitrogen Generators are designed for tonnage nitrogen consumptions. These Twin-Tower systems are designed for heavy-duty operation, where system availability in combination with low running costs are primary objectives.

Main Features:

- Outlet Flow: up to 1.500 Nm3/h
- Purity: 95% to 99,999%
- Feed air pressure: 7,5 to 10,0 bar(g)
- Discharge Pressure: 5 to 8,0 bar(g)
- N2 Dew Point: < -40 °C
- ASME VIII Div. 1 & Div. 2 or 97/23/CE (Vessels)
- SIEMENS SIMATIC PLC, HMI
- Data Logging
- N2 Pressure Sensor
- High Reliability
- Customization to define your specific need

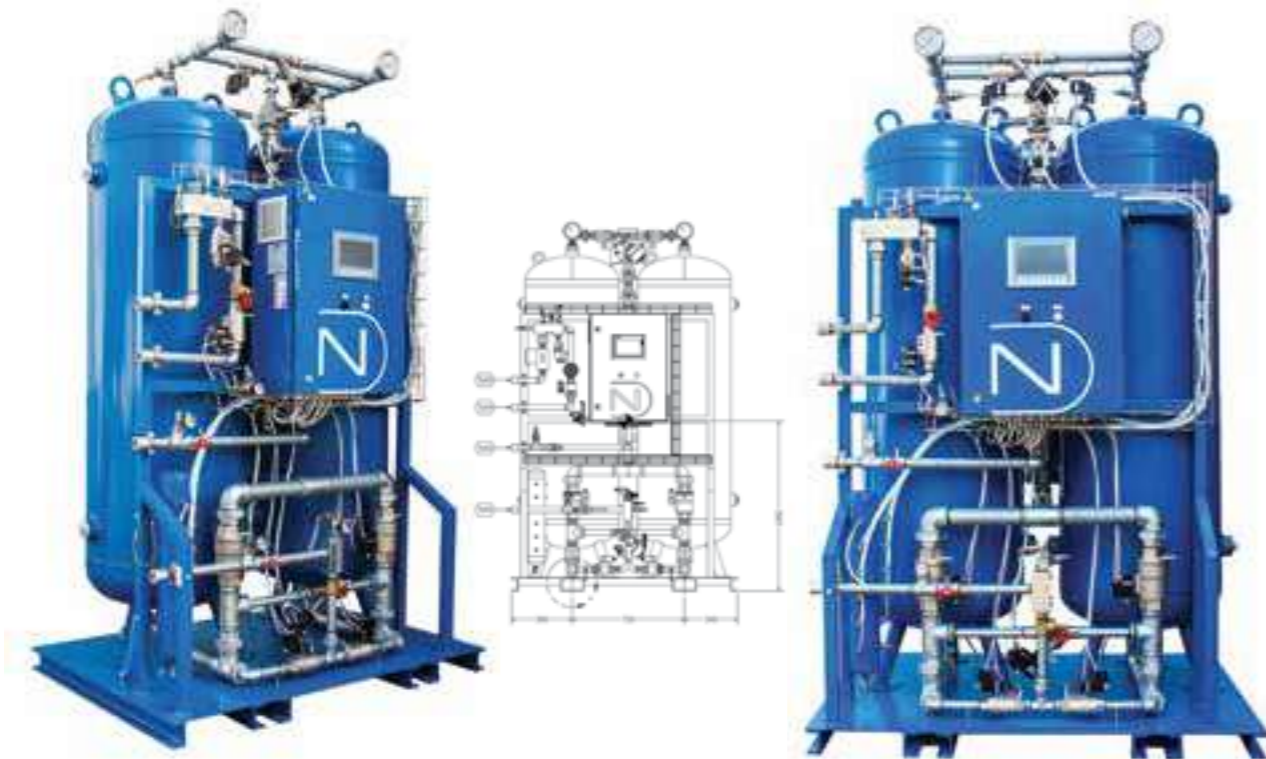

Performance of PSA Nitrogen Generator NS-100 Eco-line

OxygenContent	5 Vol.%		3 Vol.%		2 Vol.%		1 Vol.%		0.5 Vol.%		0.1 Vol.%		100 ppm		50 ppm		10 ppm		
Feed Air Pressure	barg	7.5	10	7.5	10	7.5	10	7.5	10	7.5	10	7.5	10	7.5	10	7.5	10	7.5	10
	psig	109	145	109	145	109	145	109	145	109	145	109	145	109	145	109	145	109	145
Product Flow rate(1)	m3/h	218.3	238.1	168	206.2	146.8	182.4	121.6	149	117.3	148.9	92.3	101.3	58.9	63.3	54.3	51.9	41.7	42.9
	Product pressure	barg	5.0	7.3	5.5	7.6	5.8	7.8	6.0	8.0	6.0	8.0	6.3	8.3	6.3	8.3	6.3	8.3	6.3
Feed Air Consumption(1)	m3/h	445	496	377	458	327	428	311	396	309	372	275	319	241	291	240	273	238	249
	Min. Air Receiver(2)	liter	8900	11100	7350	8700	6350	7600	5750	6900	5950	7000	5350	6200	4550	5550	4450	5200	4150
Min.N2 Receiver(2)		gallon	2351	2932	1942	2298	1677	2008	1519	1823	1572	1849	1413	1638	1202	1466	1176	1374	1096
	Dew Point(3)	C°/F	≥ -40 / -40																
Sound level Leq		dB (A) <75																	

Performance of PSA Nitrogen Generator NS-200 Eco-line

OxygenContent	5 Vol.%		3 Vol.%		2 Vol.%		1 Vol.%		0.5 Vol.%		0.1 Vol.%		100 ppm		50 ppm		10 ppm		
Feed Air Pressure	barg	7.5	10	7.5	10	7.5	10	7.5	10	7.5	10	7.5	10	7.5	10	7.5	10	7.5	10
	psig	109	145	109	145	109	145	109	145	109	145	109	145	109	145	109	145	109	145
Product Flow rate(1)	m3/h	387.4	450.5	318.1	390	280	345.3	231.9	281.7	212.4	275.6	166.2	188.6	112	113.3	100.7	95.3	75	80.8
	Product pressure	barg	5.0	7.3	5.5	7.6	5.8	7.8	6.0	8.0	6.0	8.0	6.3	8.3	6.3	8.3	6.3	8.3	6.3
Feed Air Consumption(1)	m3/h	777	936	685	863	633	807	603	747	584	688	525	607	445	545	438	508	406	467
	Min. Air Receiver(2)	liter	8900	11100	7350	8700	6350	7600	5750	6900	5950	7000	5350	6200	4550	5550	4450	5200	4150
Min.N2 Receiver(2)		gallon	2351	2932	1942	2298	1677	2008	1519	1823	1572	1849	1413	1638	1202	1466	1176	1374	1096
	Dew Point(3)	C°/F	≥ -40 / -40																
Sound level Leq		dB (A) <75																	

(1) Definition of Nm³ based on reference conditions 20 °C, 101,325 kPa(a) and dry basis. Indicated flow rates are valid for operation of the generator at atmospheric conditions 20 °C / 60 °F, 1013 mbar / 14,7 psi and 60% RH.
 (2) Smaller receiver volumes might result in lower product pressures. Please contact manufacturer for details.
 (3) Dew point at atmospheric pressure

OXYGEN GENERATORS

DS-PSA (HIGH PURITY)

UP to 99.5% O2 / ~4,5 to 45 Nm3/h

The Pressure Swing / Adsorption (PSA) process is a static separation of air gases through a specific molecular sieve capable to adsorb nitrogen under pressure. With DS-PSA has taken PSA to the next level: based on a double stage DS-PSA process, delivering an ultra-high and extremely stable oxygen concentration, an ideal alternative to traditional gas supply (cylinders or liquefied gas).

Main Features:

- ▶ Oxygen Purity: 96% to 99.5% (±0.2%)
- ▶ Outlet Pressure: 6 or 10 bar (no additional booster)
- ▶ 15" High definition color touch-screen
- ▶ Inlet air quality: ISO 8573-1: class 1.4.1
- ▶ Inlet air pressure: 8-10 bar

Model	Continuous flow(m3/h)
DS-PSA 10	2.3
DS-PSA 15	3.9
DS-PSA 20	4.5
DS-PSA 27	5.4
DS-PSA 30	6.8
DS-PSA 40	9.7
DS-PSA 50	10.8
DS-PSA 60	13.0
DS-PSA 72	15.7
DS-PSA 90	18.6
DS-PSA 100	21.1
DS-PSA 120	25.1
DS-PSA 150	34.0
DS-PSA 200	43.2



DS-PSA 72 (Sample Design)

Oxygen Purity		96%		99%		99.5%	
Oxygen Flow rate(1)		Continuous	Peak	Continuous	Peak	Continuous	Peak
		m3/h	26.0	28.5	15.5	18.0	13.5
	scfh	953.5	1037.5	573.5	654.0	486.0	570.0
Oxygen Discharge pressure	bar(g)	From 4.5 to 6 (10 bar available in option ³)					
	psig	From 65 to 87 (145 Psig available in option ³)					
Min. Air/O2 Receivers (2)	liter	1500/1500					
	gallon	396/396					

(1) Definition of Nm3 based on reference conditions 0 °C, 101,325 kPa(a) and dry basis
 Indicated flow rates are valid for operation of the concentrator at atmospheric conditions 20 °C / 70 °F, 1013 mbar / 14.7 psi and 60% humidity rate.
 (2) Smaller receiver volumes might result in lower pressures. Please contact manufacturer for details.
 (3) Without additional equipment

OXYGEN GENERATORS

PSA Modular

UP TO 95% O2 / ~2,5 to 60 Nm3/h

For industries looking for a flexible and autonomous supply of oxygen, modular oxygen generators deliver a continuous flow of Oxygen on-site, featuring multiple modules of molecular sieve, each implementing an optimized patented PSA process delivering up to 95% pure Oxygen at 6 bar. Production capacity can be easily adjusted directly on site by simple module additions without any skilled personnel.

Main Features:

- ▶ Outlet Flow: 2,5 to 60 Nm3/h
- ▶ Purity: 90% to 95%
- ▶ Discharge Pressure: 6 bar
- ▶ Adsorber Vessel Module(s) in Anodized Aluminum
- ▶ Internal Piping & Fittings in SS316
- ▶ Pneumatic Valves with Bodies in SS316L
- ▶ Exhaust Mufflers
- ▶ Local Instrumentation, incl. O2 Pressure Transmitter
- ▶ Siemens PLC and Graphical Touch Panel HMI
- ▶ Data Logging with 1 Minute Recording Frequency



They comply with the European Pressure Equipment Directive 2014/68 EU. For food applications, we can provide food grade certificates upon request.

Models	PSA Modules	Oxygen Production Flow – 95% Purity*	
		Peak Flow	
		m3/h	SCFM
OS-8	1	2.6	1.6
OS-16	2	5.3	3.3
OS-24	3	7.9	5
OS-32	4	10.4	6.6
OS-40	5	13.1	8.3
OS-48	6	15.5	9.8

* It is possible to combine two generators «master» and «slave» with various flows. Contact us to define the best combination according to the required flow.

OXYGEN GENERATORS

PSA TWIN-TOWER

From 90% to 95% / 20 to 53 m3/h

PSA oxygen generators are designed to produce oxygen at a concentration from 90% to 95%, with an exceptional stability. With a large range of capacities and various output oxygen purities. This system is based on the PSA technology (Pressure Swing Adsorption); a static separation of air gases using a specific molecular sieve that adsorbs nitrogen under pressure.

Main Features:

- Outlet Flow: 20 to 53 m3/h
- Purity: 90% - 95%
- Fully automatic process
- Various flow rates and purities available
- Remote monitoring & alarm functions
- PLC based control, Siemens SIMATIC
- External Feed Air Filters
- Adsorber Vessels according to 2014/68/UE (ASME VIII Div. 2 as option)
- Oxygen Pressure Sensor



Compressed Air/ Oxygen	
Air pressure min/ max	barg 6.0/7.5
Outlet pressure	Up to 6 bar
*Air quality	**ISO 8573-1: class 0.4.0

* Possibility to increase the outlet pressure upon request
 ** Feed air quality at air filter outlet

Operating conditions	
Ambient temperature	Min5° C -Max45° C
Humidity	40°C(80% MAX ≤31° C)* @ 50%
Power supply	230-110 V/50-60 Hz

*Specific ambient conditions handled upon request
 Do not expose to outdoor impurities (rain,sand,heavy dust)

Additional features & available options

- Containerized or skid mounted plant
- Oxygen analyzer with zirconium-oxide sensor
- Electronic product flowmeter
- Feed air/ product moisture analyzer
- Oxygen sterile filters

Performance of * PSA Oxygen Generator OS-60 Eco-Line

Oxygen Content	95 Vol, %		93 Vol, %		90 Vol, %	
Feed Air Pressure	barg	7.5	7.5	7.5	7.5	7.5
	psig	109	109	109	109	109
Product Flow rate(1)	m3/h	20	22.5	24.1	24.1	24.1
	scfh	746	839	899	899	899
Product pressure	barg	6	6	6	6	6
	psig	87	87	87	87	87
Feed Air Consumption(1)	m3/h	253.5	272.7	275.3	275.3	275.3
	scfh	9455	10172	10268	10268	10268
Min. Air Receiver(2)	liter	2500	2500	2500	2500	2500
	gallon	660	660	660	660	660
Min.O2 Receiver(2)	liter	1500	1500	1500	1500	1500
	gallon	396	396	396	396	396
Dew Point(3)	C°/F	≤ -40 / -40				
Sound level Leq	dB(A)	<75				

Performance of * PSA Oxygen Generator OS-60 Eco-Line

Oxygen Content	95 Vol, %		93 Vol, %		90 Vol, %	
Feed Air Pressure	barg	7.5	7.5	7.5	7.5	7.5
	psig	109	109	109	109	109
Product Flow rate(1)	m3/h	37.6	39.7	42.9	42.9	42.9
	scfh	1403	1482	1601	1601	1601
Product pressure	barg	6	6	6	6	6
	psig	87	87	87	87	87
Feed Air Consumption(1)	m3/h	477	479.3	489.4	489.4	489.4
	scfh	17801	17887	18264	18264	18264
Min. Air Receiver(2)	liter	2500	2500	2500	2500	2500
	gallon	660	660	660	660	660
Min.O2 Receiver(2)	liter	1500	1500	1500	1500	1500
	gallon	396	396	396	396	396
Dew Point(3)	C°/F	≤ -40 / -40				
Sound level Leq	dB(A)	<75				

(1) Definition of Nm³ based on reference conditions 20 °C, 101,325 kPa (a) and dry basis. Indicated flow rates are valid for operation of the generator at atmospheric conditions 20 °C / 60 °F, 1013 mbar / 14,7 psi and 60% RH.
 (2) Smaller receiver volumes might result in lower product pressures. Please contact manufacturer for details.
 (3) Dew point at atmospheric pressure

SPECIAL PACKAGES



PSA Oxygen Cylinder Filling Plant



OXYGEN Engineered PSA packages

TURBO COMPRESSORS

CENTRIFUGAL

AIR/GAS

Our centrifugal compressors cover a wide range of capacities from 20 m³/min to 2500 m³/min and pressures from 0.6 bar to 32 bar. These hi-tech compressors have passed class zero oil-free standard of TUV certification, simple structure, convenient installation and highly maintenance friendly plus low operation cost. Products are widely used in air separation, electronic semi-conductor, medicine, textile chemical fiber, food fermentation, steel and many other industrial sectors.





✉ Info@Airtrustco.com
🌐 www.Airtrustco.com
☎ (خط) ۰۰۱۶ ۸۸۳۶

📍 تهران، شهرک غرب
بلوار دادمان، پلاک ۱۴۸
☎ ۱۴۶۷۸۹۳۱۴۴